



1/2" Disc Type Thermostat
High Temp. Manual Reset

Type **15N**

UL·C·UR·VDE
Recognized

Dimensions

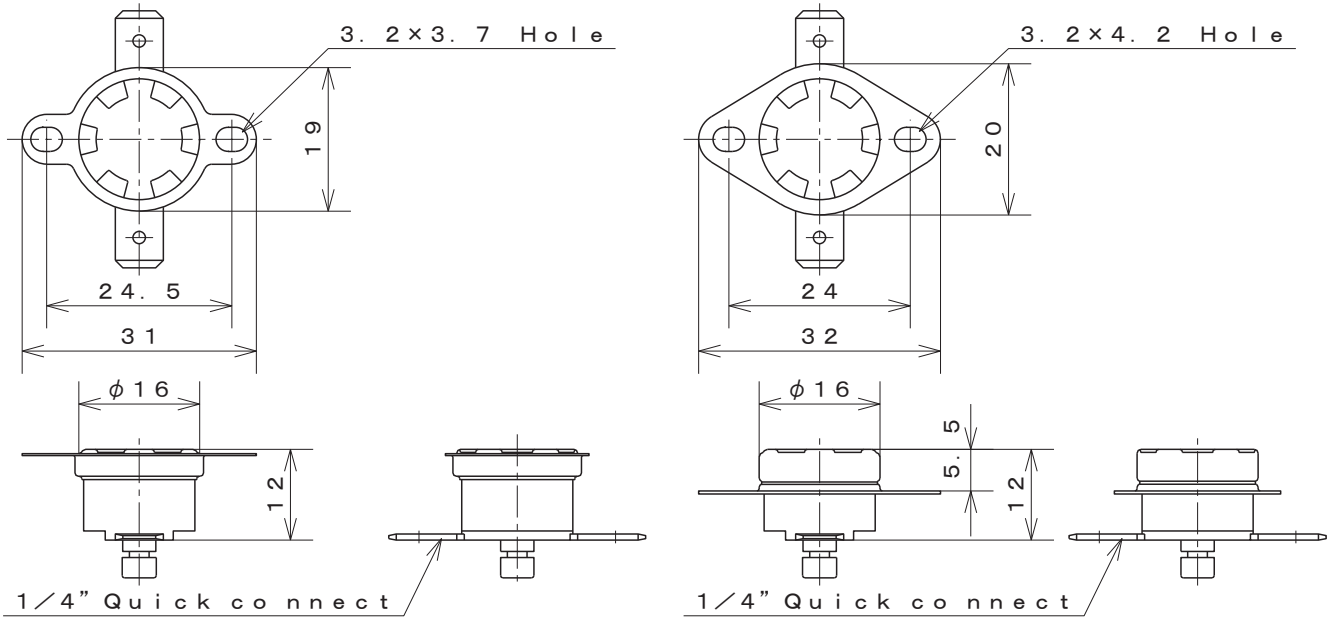

Materials of parts

Part	Material
Cap	Aluminum Copper Stainless steel
Case	Ceramic
M.arm	Beryllium Copper alloy
Terminals	Steel
Bracket	Stainless steel
Contacts	Silver-Nickel alloy (N)

Structure

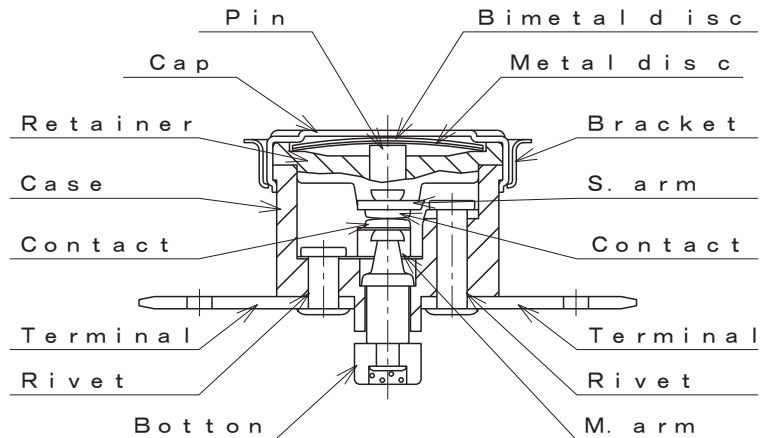

Specification

Item	Specification
1. Basic features	SPST Manual reset
2. Operation	A : Contacts open on temperature rise Not automatic reset
3. Electrical rating	AC250V/15A AC250V/10A
4. Calibration method	Hot & cold air circulation system
5. Temperature rating	Operating temperature Max. 230°C
6. Insulation resistance	Not less than 1,000MΩ/DC500V
7. Dielectric strength	Not less than AC1,500V/1min. or AC1,800V/1sec.

Standard

MITI (JET) J-58
UL 60730-1, -2-9 UL File No. E201152
DIN EN 60730-1, -2-9 VDE Licence No. 40019831